



EQUIPTER®

2000



OPERATOR'S MANUAL

DISCLAIMER

The information in this manual is provided to promote the safe use of, and assist the operator in achieving the best performance from Equipter products described herein, for their intended applications.

All rights reserved. No part of this publication may be reproduced, stored in a retrieval system, or transmitted in any form or by any means, electronic, mechanical, photocopying, recording, or otherwise, without prior written permission of New Heights, LLC.

Additional manuals can be ordered for a fee from New Heights, LLC. 717.768.0070. The Digital copy can be obtained via the Equipter Marketing Asset Library or by contacting your Equipter Sales Representative.

**View full list of patents at
www.newheightsmfg.com/patents.**

**Copyright 2022 by New Heights, LLC
Revision: 11212022**

TABLE OF CONTENTS

INTRODUCTION	1
WARRANTY	1
GENERAL INFORMATION	4
SAFETY PRECAUTION DEFINITIONS	4
PRECAUTIONS	4
SAFETY REQUIREMENTS	5
BEFORE YOU START	5
OPERATING PRECAUTIONS	6
LOAD HANDLING PRECAUTIONS	6
MAINTENANCE PRECAUTIONS	6
SAFETY DECALS	7
OVERVIEW	7
OPERATION	8
Control Panel	8
Parking Brake	8
Steering Handle	8
Start Engine	9
Stop Engine	9
DRIVING THE EQUIPTER	9
Outrigger Operation	11
DUMP BOX	11
Load Dump Box	12
Empty Dump Box	13
MAINTENANCE	16
Refill Hydraulic Oil	18
HAULING THE EQUIPTER	19
SPECIFICATIONS	20
ENGINE SPECIFICATIONS	20

ILLUSTRATIONS

Figure 1. Overhead View	iv
Figure 2. Operating Positions	2
Figure 3. Decals	3
Figure 4. Danger, Electrocution Hazard	5
Figure 5. Safety Decals	7
Figure 6. Control Panel	8
Figure 7. Parking Brake Lever (disengaged)	8
Figure 8. Steering Handle	8
Figure 9. Fuel Valve, Choke, Ignition Switch, Pull Start	9
Figure 10. Parking Brake Lever (disengaged)	10
Figure 11. Steering Handle	10
Figure 12. Forward/Reverse	10
Figure 13. Parking Brake Lever (engaged)	10
Figure 14. Outrigger Controls	11
Figure 15. Tailgate Control	12
Figure 16. Parking Brake Lever (engaged)	12
Figure 17. Lift Control	12
Figure 18. Side View (tailgate closed)	13
Figure 19. Parking Brake Lever (engaged)	13
Figure 20. Lift Control	14
Figure 21. Dump Control	14
Figure 22. Tailgate Control	14
Figure 23. Side View (tailgate opened)	15
Figure 24. Tailgate Control	15
Figure 25. Lowered (dump position)	15
Figure 26. Raised (dump position)	15
Figure 27. Dump, Lift Controls	16
Figure 28. Parking Brake Lever (disengaged)	16
Figure 29. Support Arm and Receiver	16
Figure 30. Support Arm (storage position)	17
Figure 31. Sight Gauge	17
Figure 32. Hydraulic Oil Filter	17
Figure 33. Support Arm and Receiver	18
Figure 34. Reservoir Cap	18
Figure 35. Support Arm (storage position)	19
Figure 36. Brackets (right)	19
Figure 37. Brackets (left)	19

INTRODUCTION

This manual is furnished to you, the owner/operator, as a guide to get the greatest benefit from your Equipter. New Heights, LLC wants you to be able to get the most use out of your machine through safe and efficient operation.

Before attempting to operate this machine, carefully read all sections of this manual. Be sure that you thoroughly understand all of the safety information and operating procedures.

Pay special attention to the Safety Precautions and Requirements, particularly all **DANGER, WARNING**, and **CAUTION** notices included in this manual. These items combined, form the guidelines for promoting a safe and efficient operating environment, along with continuous, reliable service and minimum down time.

NOTE: Directional reference is as follows: the front is toward the operator controls and the back is the tailgate.

Throughout this manual, reference is made to the transport position and raised positions (See Figure 2).

NOTE: Some equipment depicted in illustrations may not reflect exact production model configurations.

NOTE: All safety, operating, and servicing information reflects current production models at the time of publication of this manual.

NOTE: New Heights, LLC reserves the right to discontinue models at any time, change specifications, and improve design without notice and without incurring obligation on goods previously purchased and to discontinue supplying any part listed, when the demand does not warrant production.

WARRANTY

This Equipter is designed and manufactured to high quality standards. New Heights, LLC, therefore, guarantees this machine to be free from defects in workmanship and materials for two years from purchase date. Warranty provides for replacement parts but does not include the labor to replace defective parts.

Vendor components are warranted separately by their specific manufacturer.

Warranty does not cover normal wear or failure due to hydraulic oil contamination.

Misuse, abuse, misapplication, and unauthorized alterations will void this warranty.

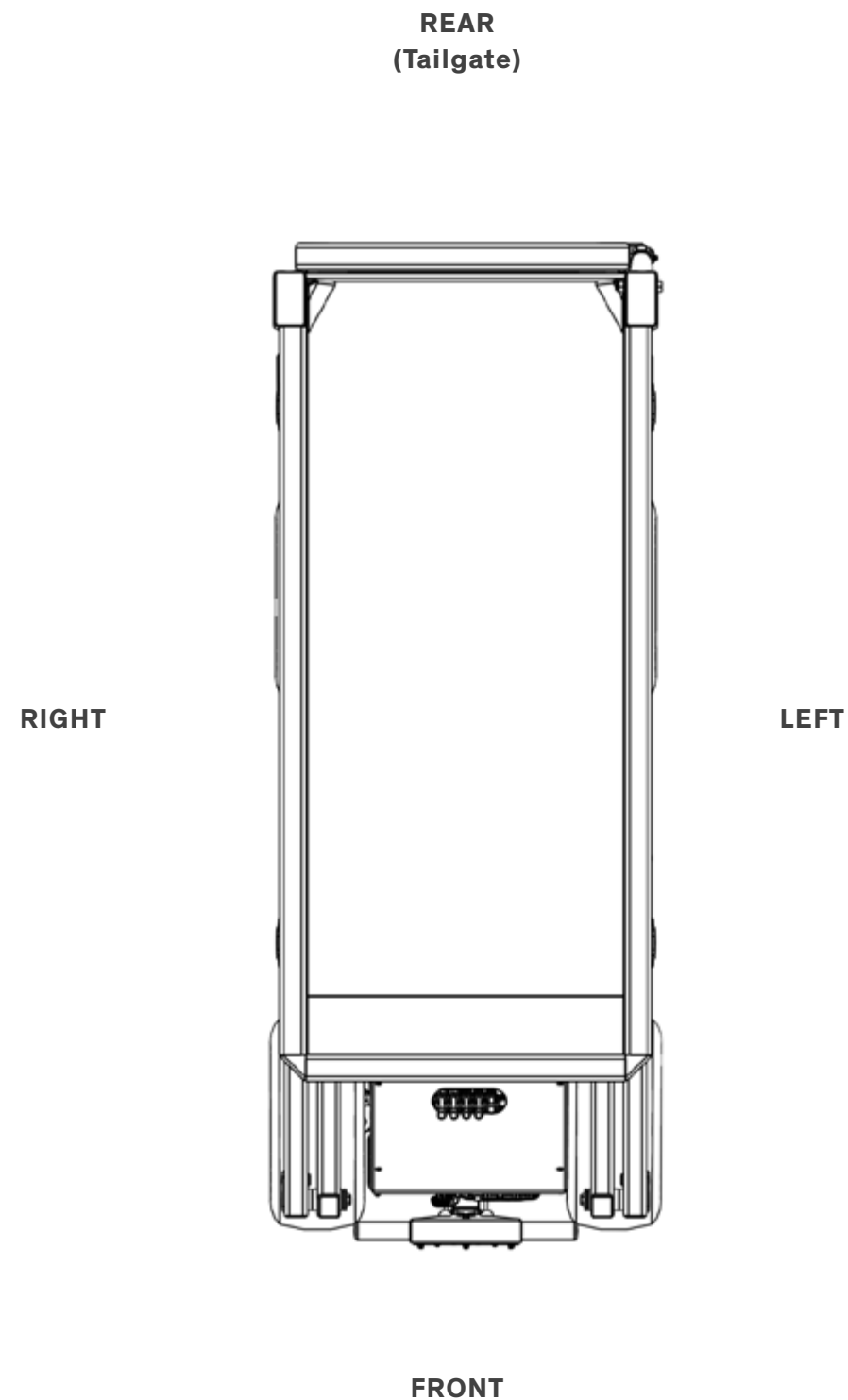
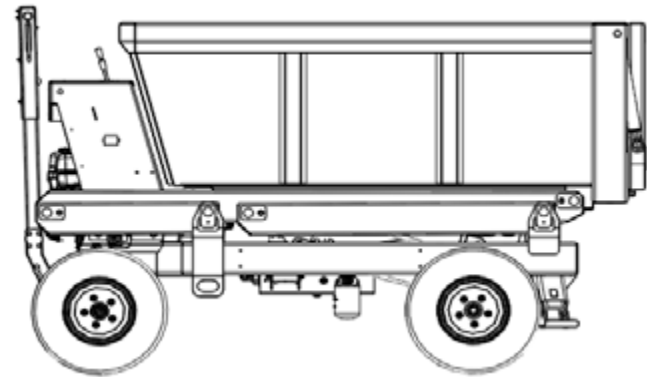
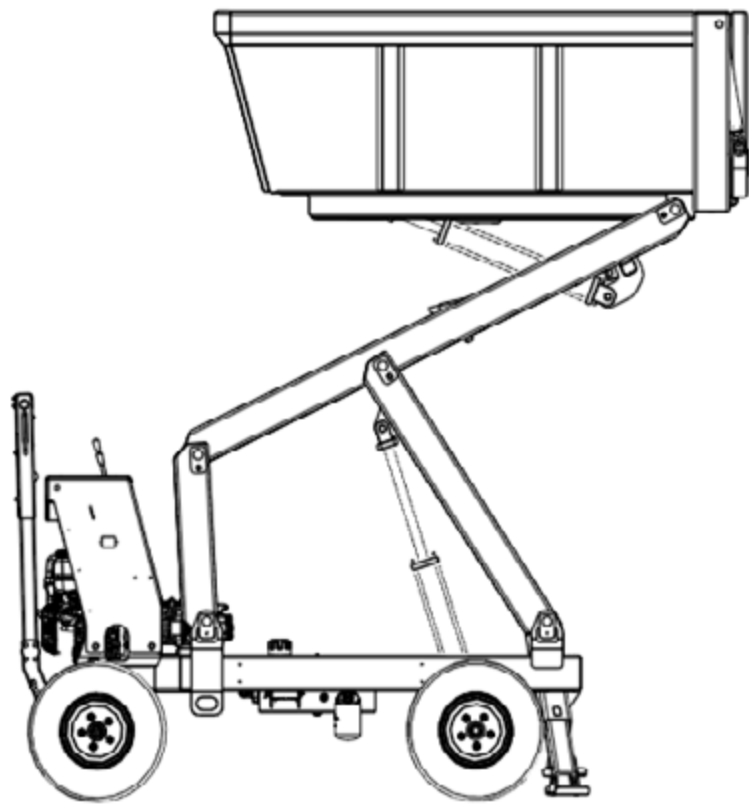

Figure 1. Overhead View



Transport Position



Raised Position

Figure 2. Operating Positions





DANGER

To Prevent serious injury or death securely latch support arm when working under equipment. Place dump box in it's dump position but keep lift completely down.



DEC-SFT-015

MUST READ & UNDERSTAND
 The Operator's Manual completely before operating this machine.
 Contact New Heights, LLC at 855.378.4783 to obtain additional manuals.
 View full list of patents at www.newheightsmfg.com/patents.



DANGER

NO RIDERS OR PASSENGERS
 Never allow riders or passengers while moving the machine or operating controls for outriggers or dump box. Dump box must be in transport position before moving or driving. Machine must be level and all outriggers stationed securely on solid ground at all times when not in transport position. Never move or adjust outriggers unless dump box is in complete transport position.

ELECTROCUTION HAZARD
 This machine is not insulated. Death or serious injury will result from contact with or inadequate clearance from energized conductors. Maintain a safe clearance from electrical power lines and apparatus. You must allow for sway, rock, or sag.



WARNING

This product can expose you to chemicals including soots, tars, and mineral oils, which are known to the state of California to cause cancer, and carbon monoxide, which is known to the state of California to cause birth defects or other reproductive harm. For more information go to www.P65Warnings.ca.gov

DEC-200-003A





DRIVE LEVER

← REVERSE FORWARD →



DEC-OPR-001A



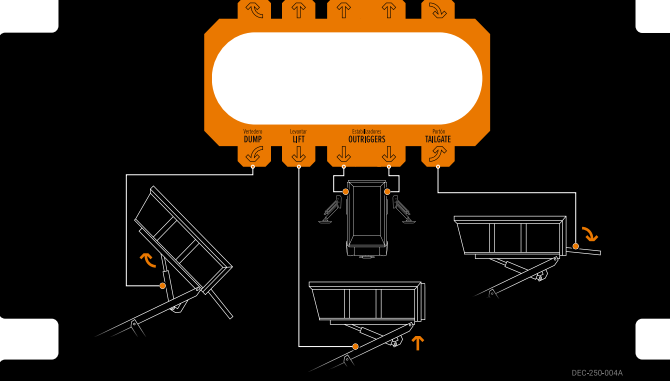

WARNING
PINCH POINT HAZARD



All outriggers must be secured on the ground and machine leveled at all times if the container is not in transport position.

DEC-OPR-004A



WARNING



TO PREVENT SERIOUS INJURY OR DEATH STAY BACK 10 FEET FROM TAIL GATE.

DEC-SFT-005



WARNING

HOT EXHAUST

DEC-SFT-001



WARNING



A MOVING OUTRIGGER CAN CAUSE SERIOUS CRUSHING INJURY. Do not operate any outrigger unless you or a single person can see that all personnel are clear of the outrigger and it's ground contact point.

DEC-SFT-002

HYDRAULIC OIL ONLY
 Chevron Rando HD PREMIUM OIL MV CONTOUR DEC-OPR-004



WARNING



PINCH POINT HAZARD

DEC-SFT-004

MUST BE PARKED ON LEVEL GROUND



PARKING BRAKE

DISENGAGED



ENGAGED

DEC-OPR-003A

Figure 3. Decals

GENERAL INFORMATION

The purpose of this manual is to provide safe operating and maintenance procedures for the intended use of this machine. It is important that all information in this manual is READ and UNDERSTOOD before operating the Equipter.

Since the manufacturer has no direct control over machine application and operation, it is the responsibility of the operator to conform to good safety practices in the implementation of this machine.

This section is composed of various warnings and safety tips that must be followed.

SAFETY PRECAUTION DEFINITIONS

Dangers, Warnings, Cautions, and Notes are strategically placed throughout this manual to further emphasize the importance of personal safety, qualifications of operating personnel, and proper use of this machine in its intended application.

These precautions supplement and/or complement the safety information decals affixed to the unit and include headings that are defined as follows:



Indicates an imminently hazardous situation which, if not avoided, will result in death or serious injury.



Indicates a potentially hazardous situation or practice which, if not avoided, could result in death or serious injury.



Indicates potentially hazardous situation or practice which, if not avoided, will result in damage to equipment and/or minor injury.

NOTE: Indicates a situation that could result in damage to the equipment or other property.

PRECAUTIONS

The primary responsibility for safety with the equipment falls to the operator. It is the skill, care, common sense, and good judgement of the operator that determines how efficiently and safely the job is performed. Know the equipment before you start. Know the capabilities, dimensions, and how to operate all the controls. Visually inspect the equipment before starting and never operate equipment that is not in proper working order with all safety devices in place and operating.



Prevent death or serious injury.

Modification of the equipment, including removal or modification of safety and identification decals, without the written consent of the manufacturer is a safety violation and is strictly prohibited.



Electrocution hazard.

This machine is not insulated and does not provide protection from contact with, or proximity to an electrically energized conductor. Maintain the minimum safe distance from an electrically energized conductor.

Working in the vicinity of power lines is a serious hazard and special precautions must be taken.

Any electrical power line shall be considered to be an energized line until the owner of the line or the electrical utility authorities indicate that it is not an energized line and it has been visibly grounded.

Contact with power lines is not required for electrical power to arc between the line and equipment.

Always be aware of the power carried by the power lines. Allow sufficient time and distance to react to swaying or sagging power lines. The following table provides the minimum distances which must be maintained.

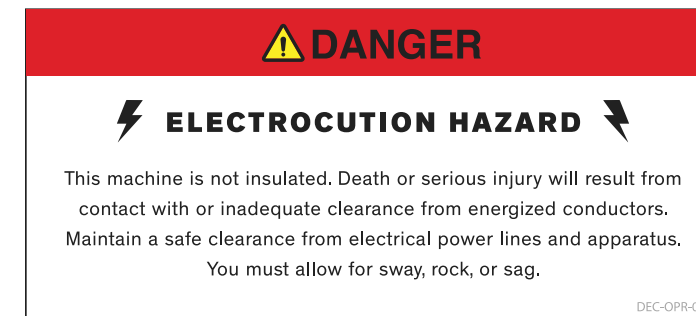

Figure 4. Danger, Electrocution Hazard

0 volts to 300 volts	Avoid Contact
300 volts to 50 kv	10 ft. (3.05 m)
50 kv to 200 kv	15 ft. (4.6 m)
200 kv to 350 kv	20 ft. (6.1 m)
350 kv to 500 kv	25 ft. (7.6 m)
500 kv to 750 kv	30 ft. (9.2 m)
750 kv to 1000 kv	45 ft. (13.7 m)

SAFETY REQUIREMENTS

All operators must be 18 years of age or older and must have the ability to operate the machine safely and engage the parking brake.

Parking brake must always be engaged unless the Equipter is being driven by its own drive system.

Before dumping, always lower outriggers and verify that outriggers are firmly stationed on secure footing.

The dump box must be in the transport position before driving the Equipter.

Always use the bubble level to help confirm that the Equipter is completely level any time the dump box is not in the transport position.

BEFORE YOU START

Know the equipment. Know how to operate all controls and know emergency shutdown procedures. Make sure all safety devices are in place.

Do not wear loose clothing or items such as rings and watches around the equipment. They could get caught in moving parts and lead to death or serious injury.

Inspect the equipment. Check for missing shields, loose bolts, and twisted or damaged hydraulic hoses. Be sure all operational decals are in place and legible. Never operate a damaged or unsafe machine.

Keep all controls free of dirt, grease, oil, and water.

Keep area clear of tools, rags, and extra parts.

Keep equipment clean.

OPERATING PRECAUTIONS

Know the work area before you begin. Observe any potential hazard areas such as soft ground, drop-offs, rocks, and other obstacles.

Do not drive on hills above a 5% grade. Be aware of wet conditions that may allow the machine to lose traction and slide on a hill.

Always lower outriggers and verify that outriggers are firmly stationed on secure footing.

Observe overhead electrical and phone lines. Be sure equipment will safely clear them.

Be aware of others in the work area. Be sure others know when and where you will be working. Make sure no one is under or behind equipment.

Always make sure no one is under or behind the equipment when opening or closing the tailgate.

Never try to board equipment while its moving.

Never allow riders or passengers.

This machine is not to be used as a personnel lift.

Be aware of what is going on around you. Watch for others who may not be watching out for themselves.

LOAD HANDLING PRECAUTIONS

Verify machine is level and outriggers are lowered to the ground.

Parking brake must be engaged prior to operating the dump box.

Check clearance on both sides before outriggers are lowered. Make sure personnel are clear of outriggers.

Never allow riders or passengers.

MAINTENANCE PRECAUTIONS

Replace all safety shields and guards when finished performing maintenance. Do not operate the machine with protective equipment removed.

Never perform maintenance or adjustments while the equipment is operating. Turn off the engine when performing maintenance to prevent accidental movement.

Make sure all operating and residual pressures are relieved before working on a hydraulic system.

Shut engine off and operate all the controls to relieve any pressure.

Use only manufacturer recommended replacement parts. Other parts may be substandard in fit and quality.

SAFETY DECALS

Safety decals are located on the Equipter to identify both operational and maintenance hazards. These safety decals are placed according to the hazard in that area of the machine. Read and understand each of the safety decals and the hazard it references.

These safety messages are additional information to the safety content already described in this section of the operator's manual.

All safety decals must be legible at all times. Keep them clean by using soap and water, (avoid using harsh chemicals or pressure washing). If the safety decal is no longer legible, replace it with a new one.

Contact your dealer or Equipter for new decals. The part number of the decal is located on the decal and on the images of the safety decals that follow.



Figure 5. Safety Decals

OVERVIEW

The Equipter is designed for contractors to simplify cleanup. It takes this labor-intensive, time-consuming job to a level of automation not found previously.

This machine will not only simplify your work, it reduces traffic through flower beds, around fences, and over shrubbery. Your customers will quickly see the benefits of less wear and tear through their yards.

The Equipter is a simple and durable time saver.

The Equipter is a self-propelled vehicle. It can be navigated into place across yards for trash collection.

When finished or full, it can be driven out of the yard and dumped into a truck or dumpster.

OPERATION

Control Panel:

- A. Dump Box Lever
- B. Lift Lever
- C. Right Outrigger Lever
- D. Left Outrigger Lever
- E. Tailgate Lever

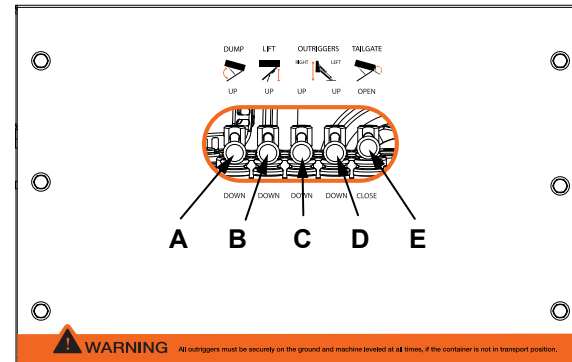

Figure 6. Control Panel

Parking Brake:

- F. Parking Brake Lever

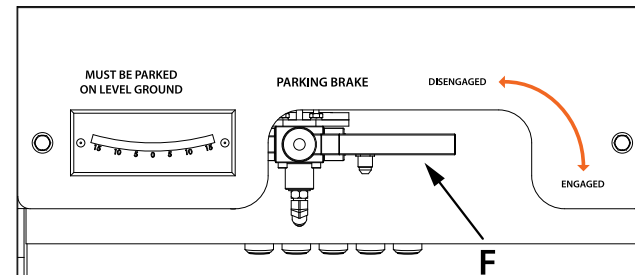

Figure 7. Parking Brake Lever (disengaged)

Steering Handle:

- G. Steering Handle
- H. Forward Drive Lever
- I. Reverse Drive Lever

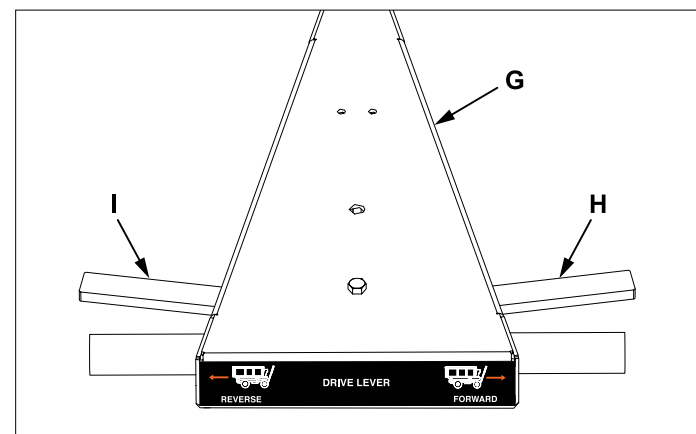

Figure 8. Steering Handle

Start Engine

This section is intended to provide basic steps to operate the engine on the Equipter (Figure 9). Additional information regarding engine operation and maintenance is available within the OEM Engine Manual supplied with the Equipter.

1. Move the fuel valve lever (A) to the on position.
2. To start a cold engine, move the choke lever (B) to the closed position.
3. Turn the engine switch (C) to the on position.
4. Move the throttle about 1/3 of the way toward the maximum position.
5. Pull the starter grip (D) briskly. Return the starter grip gently.
6. Gradually move the choke lever to the open position as the engine warms up.

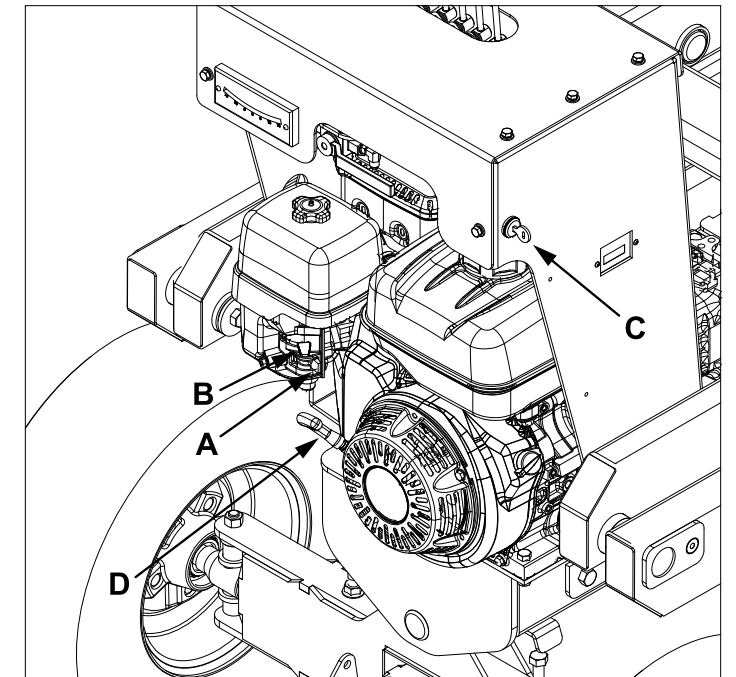

Figure 9. Fuel Valve, Choke, Ignition Switch, Pull Start

Stop Engine

1. Move throttle to minimum position.
2. Turn engine switch (C) to off position.
3. Move fuel valve lever (A) to off position.

DRIVING THE EQUIPTER

The Equipter is self-propelled and can be driven across lawns and driveways. It is not intended to travel across rough terrain, up or down steep hills, or through soft ground. The Equipter can be driven across uneven ground but be aware of the load. When loaded with debris, the center of gravity is higher which could result in rollover.

CAUTION

Equipter may roll if parking brake is not engaged. Always engage parking brake when parking the Equipter.

DANGER

Prevent contact with overhead obstacles and/or rollover. Always place the dump box and lift in the transport position (lowered) and fully raise the outriggers before driving the Equipter.

NOTE: When initially driving the Equipter, it is recommended that the engine be operated at a slow speed until the operator is familiar with the controls and how the machine reacts to the controls.

NOTE: Directional reference is as follows: the front is toward the drive handle, back is the tailgate.

1. Move parking brake lever (F) to disengaged position as shown.

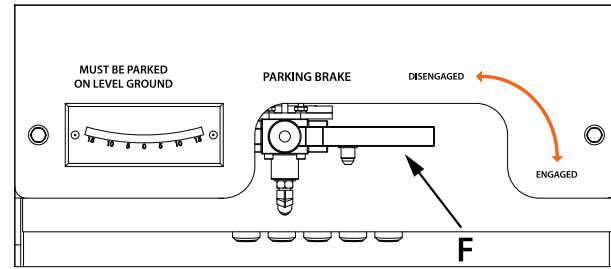

Figure 10. Parking Brake Lever (disengaged)

2. Pull steering handle (G) down to operation position.

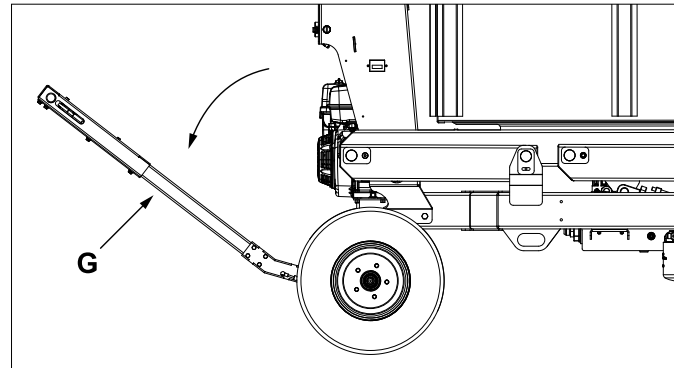

Figure 11. Steering Handle

3. Forward/reverse travel are controlled by drive levers on steering handle. Pull right drive lever (H) to travel forward. Pull left drive lever (I) to travel in reverse. When released, the lever will return to neutral and the machine will stop.

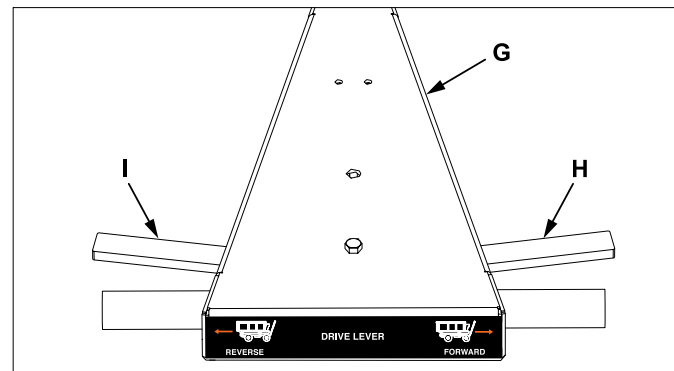

Figure 12. Forward/Reverse

4. Move parking brake lever (F) to engaged position as shown.

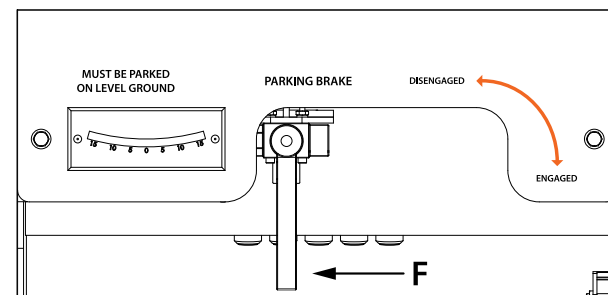

Figure 13. Parking Brake Lever (engaged)

Outrigger Operation

⚠ WARNING

Prevent equipment rollover.

Never raise dump box until outriggers are down and in contact with the ground or surface and Equipter is level.

Do not raise dump box or lift until outriggers are down and in contact with the ground or surface and Equipter is level. Always leave clearance for the outriggers when positioning the Equipter.

1. Drive machine to desired position.
2. Park machine on a firm, level surface.
3. Move levers (C) and (D) to down position to lower outriggers and level the machine side-to-side. Use cribbing or blocking under outriggers if surface is soft.

NOTE: Fully raise outriggers before moving the Equipter.

4. Move levers (C) and (D) to up position to raise outriggers. Verify outriggers are fully raised.

DUMP BOX

Engine speed effects the speed of the dump box. While it may be necessary to increase engine speed above idle, full throttle is not recommended. The hydraulics are powerful enough to cause damage to a building if contact occurs.

⚠ DANGER

Electrocution Hazard.

This machine is not insulated and does not provide protection from contact with, or proximity to an electrically energized conductor. Maintain the minimum safe distance from an electrically energized conductor.

⚠ WARNING

Prevent equipment rollover.

Never move or adjust the outriggers unless the dump box and lift are in the transport position.

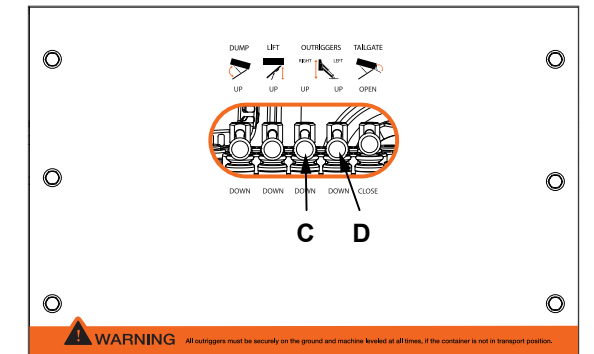

Figure 14. Outrigger Controls

⚠ WARNING

Prevent equipment rollover.

Never raise dump box unless outriggers are down and in contact with the ground or surface and Equipter is level. Never drive the Equipter with the dump box raised.

Load Dump Box

1. Drive machine to desired position.
2. Verify tailgate is in closed position by moving tailgate lever (E) down on control panel.

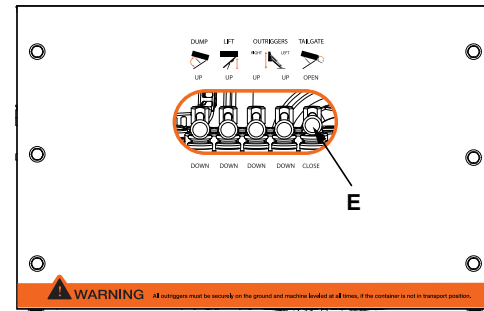

Figure 15. Tailgate Control

3. Move parking brake lever (F) to engaged position as shown.

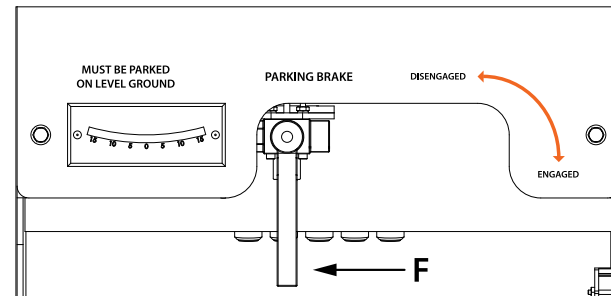

Figure 16. Parking Brake Lever (engaged)

4. Lower the outriggers and verify machine is level. See Outrigger Operation.

WARNING

Prevent equipment rollover.

Never move the Equipter and/or adjust the outriggers unless the dump box and lift are in the transport position.

5. Move lift lever (B) to the up position to raise lift to desired position. Dump box will self-level while raising. Release lever to stop lift movement.

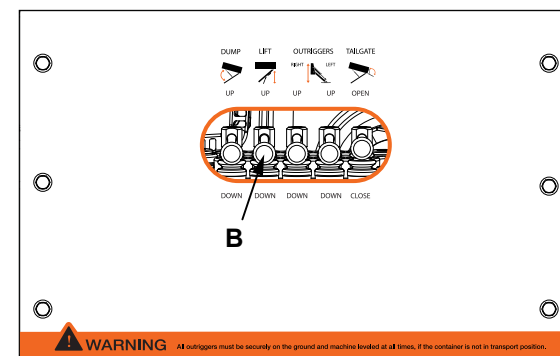

Figure 17. Lift Control

WARNING

Crush Hazard.

A raised lift can fall. Never enter the area under a raised lift.

6. Move lift lever (B) to the down position to lower lift. Dump box will self-level while lowering. Release lever to stop lift movement.

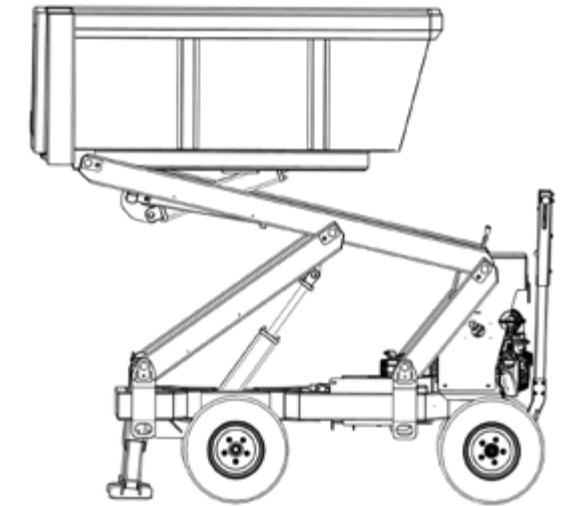

Figure 18. Side View (tailgate closed)

Empty Dump Box

The dump box can be emptied from any height or extension point.

DANGER

Electrocution Hazard.

This machine is not insulated and does not provide protection from contact with, or proximity to an electrically energized conductor. Maintain the minimum safe distance from an electrically energized conductor.

1. Drive machine to desired position.
2. Move parking brake lever (F) to engaged position as shown.
3. Lower outriggers and verify machine is level (see outrigger operation). If lift will be raised, go to step 4. If dump box will be emptied with lift in the down position, go to step 5.

WARNING

Crush Hazard.

A raised, unsupported dump box can fall. Never enter the area under a raised dump box without the support arm in place to prevent the dump box from lowering. Never support a loaded dump box with the support arm. Dump box must be empty.

WARNING

Crush Hazard.

A raised lift can fall. Never enter the area under a raised lift.

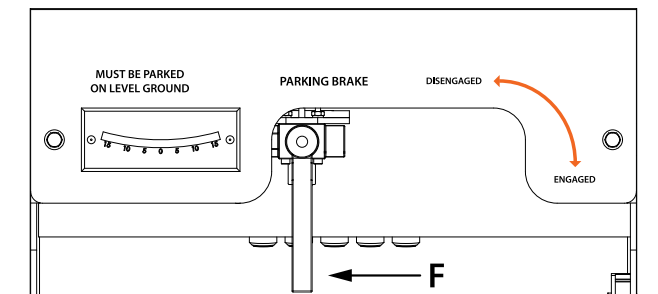

Figure 19. Parking Brake Lever (engaged)

WARNING

Prevent equipment rollover

Never raise dump box unless outriggers are down and in contact with the ground or surface and Equipter is level. Never drive the Equipter with the dump box raised.

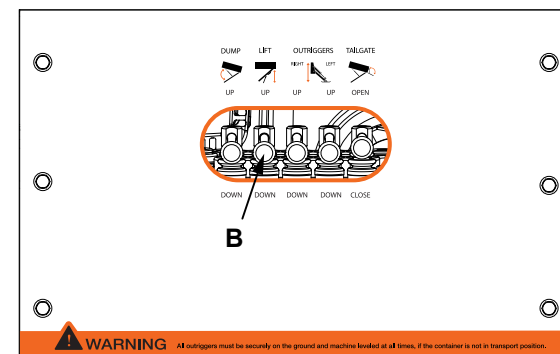

Figure 20. Lift Control

4. Move lift lever (B) to the up position to raise lift to desired position. Dump box will self-level while raising and lowering. Release lever to stop lift movement.

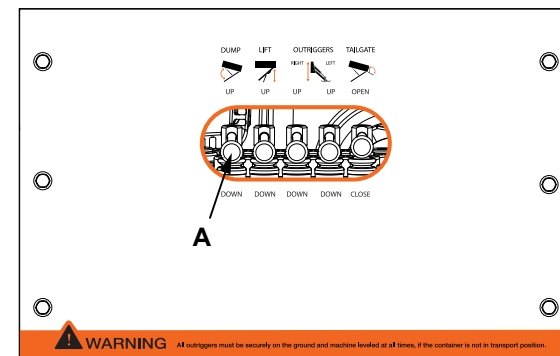

Figure 21. Dump Control

5. Move dump lever (A) to the up position to raise dump box. Release lever to stop lift movement.

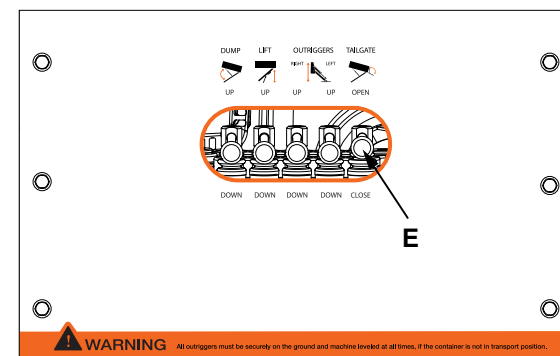

Figure 22. Tailgate Control

6. Move tailgate lever (E) up to lower tailgate. Slowly raise dump box as contents begin to unload.

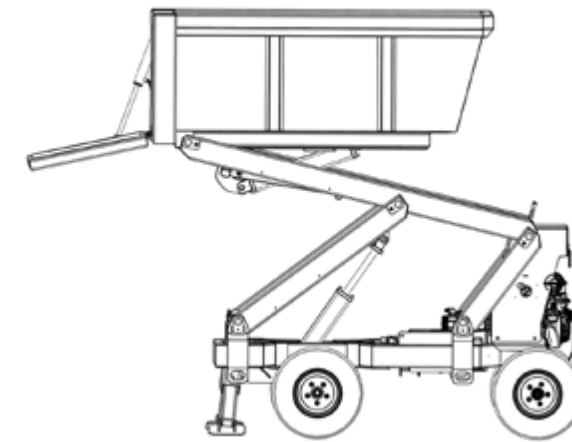

Figure 23. Side View (tailgate opened)

7. After all debris is clear of dump box, move tailgate lever (E) down to close tailgate.

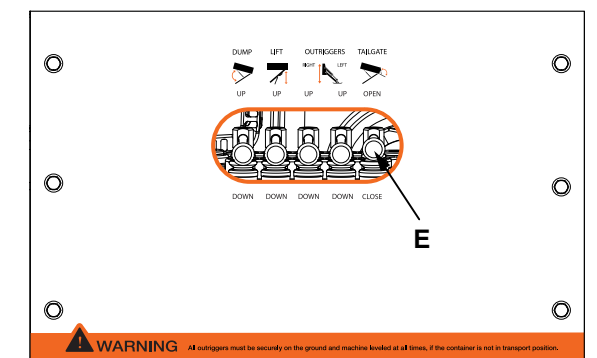

Figure 24. Tailgate Control

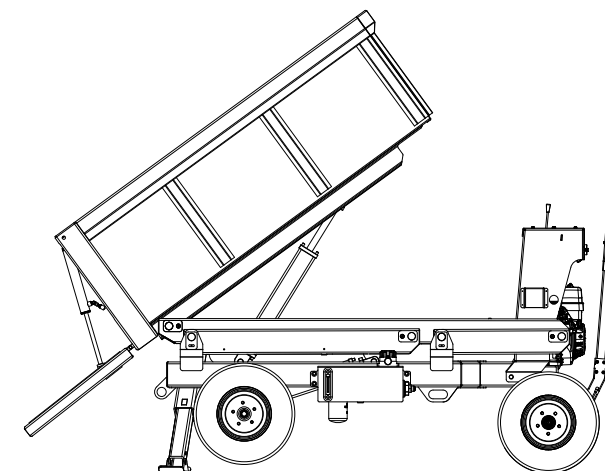

Figure 25. Lowered (dump position)

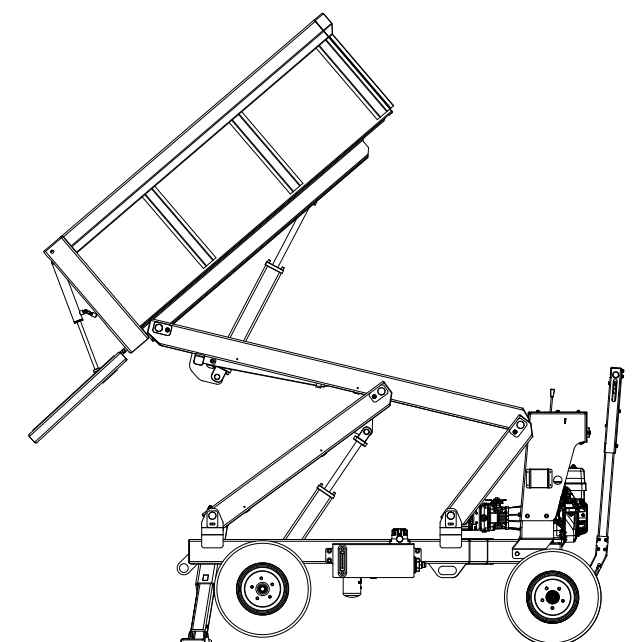

Figure 26. Raised (dump position)

8. Move dump lever (A) to the down position to lower dump box. Release lever to stop lift movement.

9. If lift is raised, move lift lever (B) to the down position to lower lift. Release lever to stop lift movement.

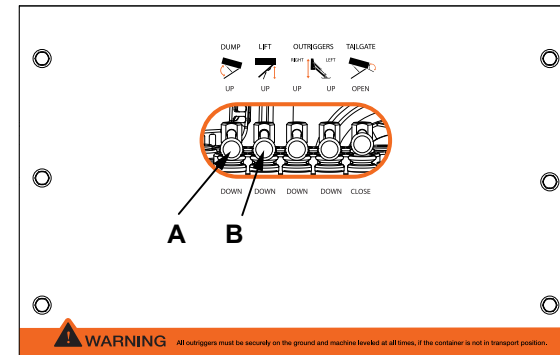

Figure 27. Dump, Lift Controls

10. Raise the outriggers. See Outrigger Operation.

11. If ready to move Equipter, move parking brake lever (F) to disengaged position as shown and drive Equipter to desired position.

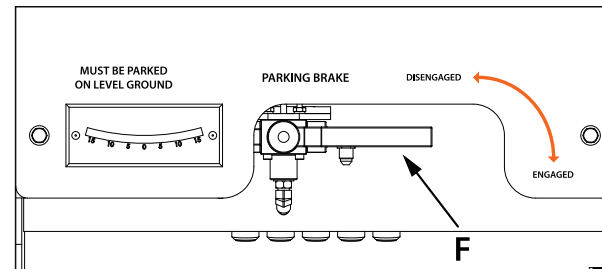

Figure 28. Parking Brake Lever (disengaged)

MAINTENANCE

It is important that the Equipter be maintained and serviced on a regular basis. Replace all worn or damaged parts.

For service and maintenance under the dump box, use the following steps.

1. Lower the outriggers, engage parking brake and verify machine is level. See Outrigger Operation.

2. Empty the dump box. Never use support arm on a loaded dump box.

3. Tilt dump box to the raised position and place support arm (A) into receiver (B).



WARNING

Crush Hazard.

A raised, unsupported dump box can fall. Never enter the area under a raised dump box without the support arm in place to prevent the dump box from lowering. Never support a loaded dump box with the support arm. Dump box must be empty.

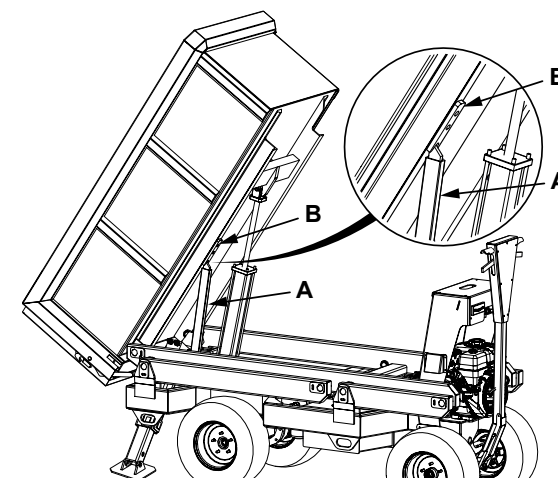

Figure 29. Support Arm and Receiver

4. After service is completed, place support arm (A) in storage position and lower dump box.

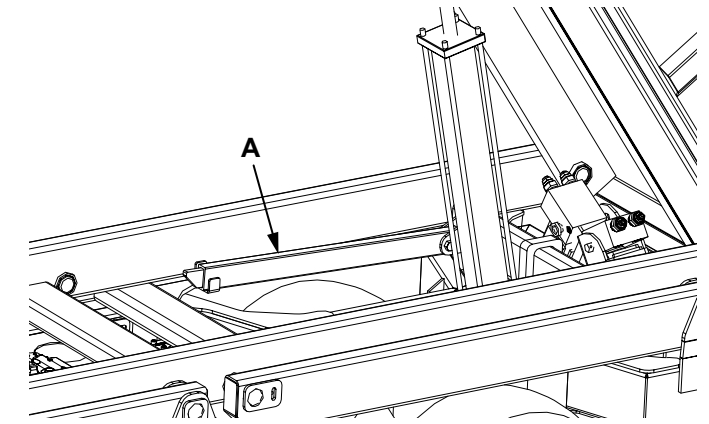

Figure 30. Support Arm (storage position)

Check the following every 8 hours of operation or daily.

1. Check engine oil level - Refer to OEM Engine Manual.

2. Check hydraulic fluid level.

a. Park the Equipter on level ground.

b. Engage parking brake.

c. Fully lower lift and dump box.

d. Fully retract outriggers.

e. The hydraulic oil level should be visible in the sight gauge (B). Normal oil level should rest at the thick black line near the top of the gauge. If necessary to refill, use only approved hydraulic oil and see Refill Hydraulic Oil.

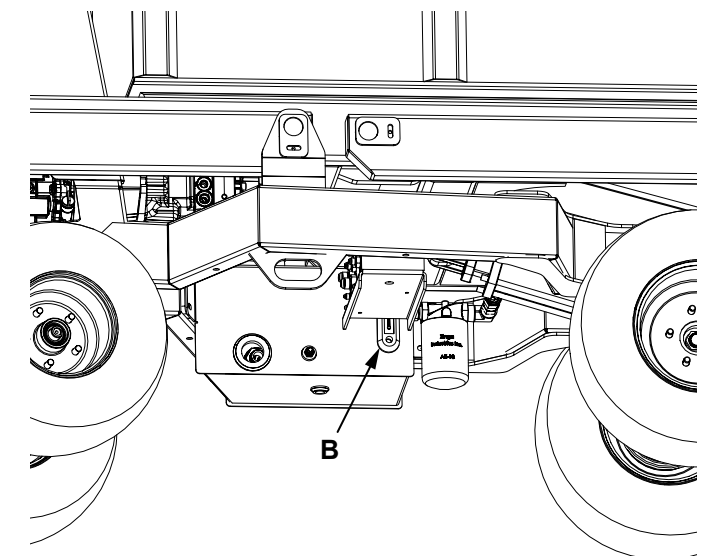

Figure 31. Sight Gauge

Change hydraulic oil filter (C) every 6 months and the hydraulic oil every 3 years.

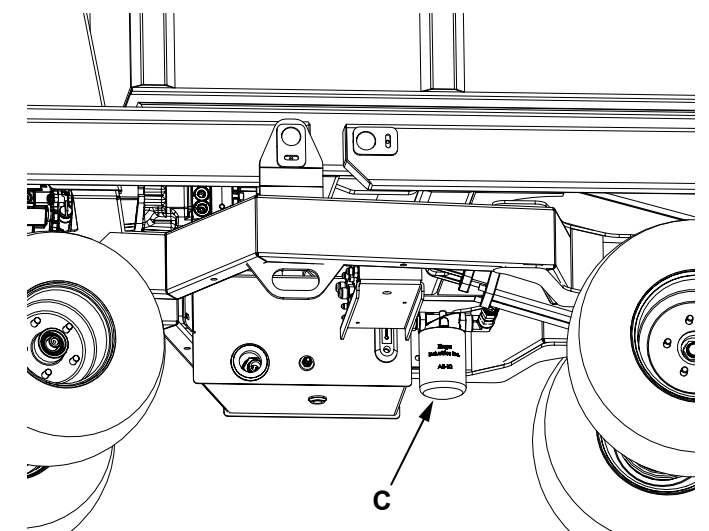

Figure 32. Hydraulic Oil Filter

The following are approved oil sources:

Check the following every 40 hours of operation.

1. Check tire inflation pressure. Tire inflation pressure is listed on the sidewall of the tire.
2. Check that all wheel lug nuts are tight.

Chevron	Rando HD Prem MV Hyd Oil
Mobil	Mobil DTE 12 or 12M
Castrol	Aerial Lift

Refill Hydraulic Oil

⚠ WARNING

Crush Hazard.

A raised, unsupported dump box can fall. Never enter the area under a raised dump box without the support arm in place to prevent the dump box from lowering. Never support a loaded dump box with the support arm. Dump box must be empty.

1. Lower the outriggers, engage parking brake and verify machine is level. See Outrigger Operation.
2. Empty the dump box. Never use support arm on a loaded dump box.
3. Tilt dump box to the raised position and place support arm (A) into receiver (B).

⚠ WARNING

Crush Hazard.

A raised lift can fall. Never enter the area under a raised lift.

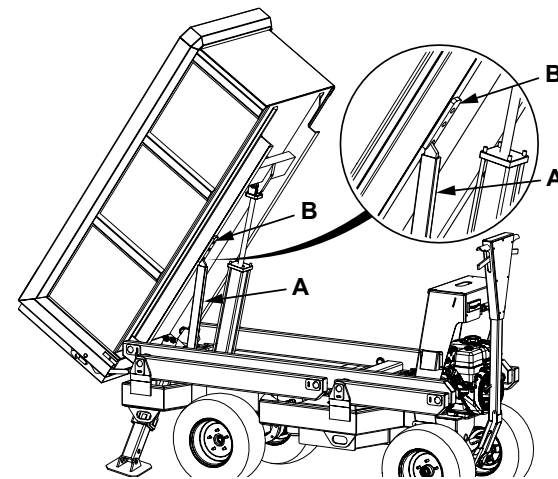

Figure 33. Support Arm and Receiver

4. Remove reservoir cap (C) and add hydraulic oil as necessary. Replace cap (C).

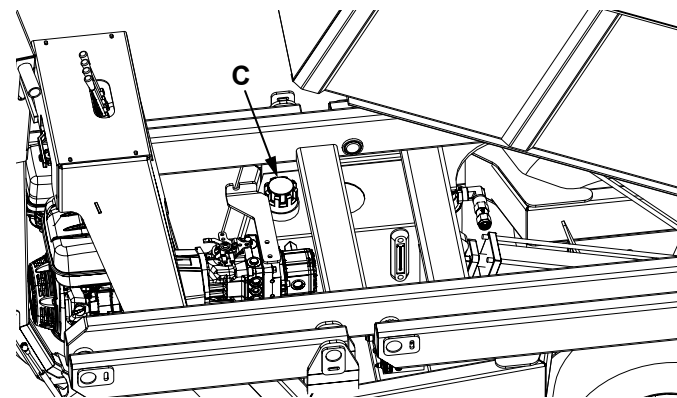

Figure 34. Reservoir Cap

5. After service is completed, place support arm (A) in storage position and lower dump box.
6. Recheck hydraulic oil level on sight glass.

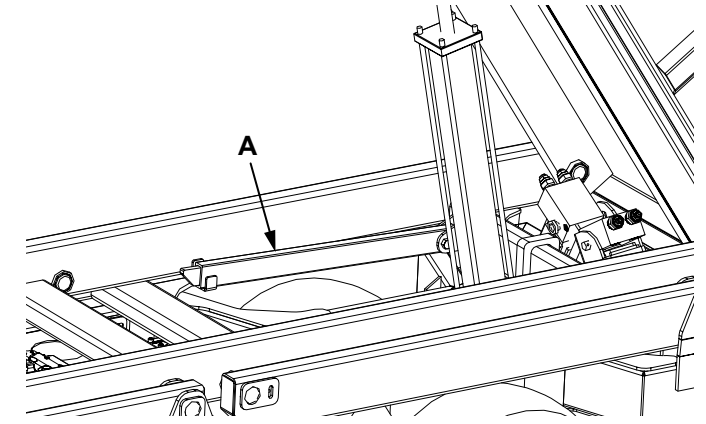

Figure 35. Support Arm (storage position)

HAULING THE EQUIPTER

Brackets (A) are provided on each side to tie down the Equipter while hauling on a truck or trailer.

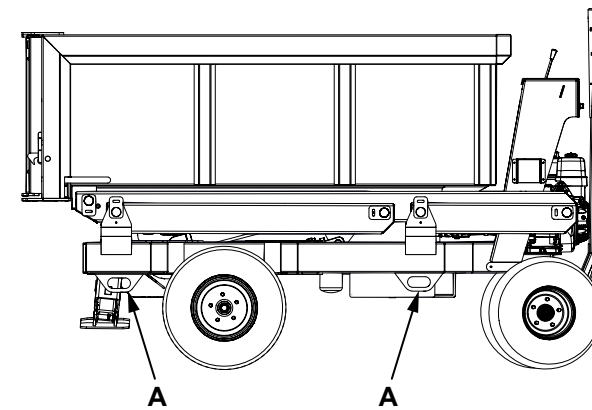

Figure 36. Brackets (right)

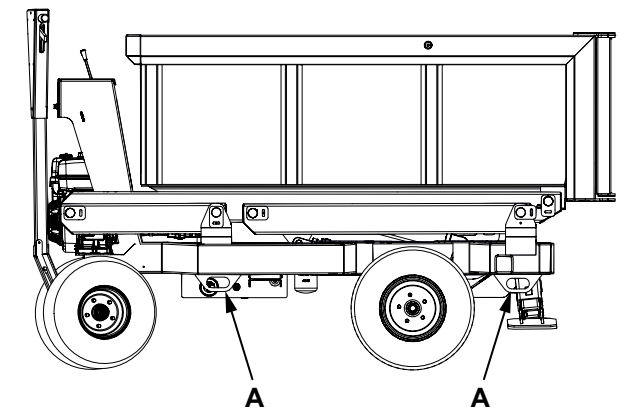

Figure 37. Brackets (left)

SPECIFICATIONS

Empty Weight	1600 lbs
Overall Width	2 ft 11 in
Overall Length.....	7 ft 10 in
Lift Capacity.....	1500 lbs
Lift Height.....	7 ft 2 in
Dump Box Size.....	1.13 Cubic Yards
Engine Power.....	8.5 hp
Hydraulic Tank Capacity	4.91 Gallons
Oil Type.....	Chevron® Rando HD Prem MV Hyd Oil, Mobil® DTE 12 or 12M or Castrol® - Aerial Lift

ENGINE SPECIFICATION

Engine Type.....	Air-cooled 4-stroke OHV
Engine Power.....	9 hp
Bore x Stroke.....	77 X 658 mm
Displacement.....	16.5 cu in Net Power Output*
Horsepower	9 HP (6.3 kW) @ 3,600 rpm
Net Torque.....	14.1 lb-ft (19.1 Nm) @ 2,500 rpm
PTO Shaft Rotation.....	Counterclockwise (from PTO shaft side)
Compression Ratio	8.5:1
Carburetor.....	Butterfly Float Type
Ignition System.....	Digital CDI With Variable Timing
Starting System.....	Recoil/electric
Lubrication System.....	Splash
Governor System.....	Centrifugal Mass Type
Air Cleaner	Dual Element
Oil Capacity.....	1.16 US. qt (1.1liters)
Fuel Tank Capacity.....	5.6 US. qts (5.3 liters)
Fuel Unleaded	86 octane or higher
Dry Weight.....	55 lbs (25 kg)

49 Eagle Drive, Suite 102, Leola, PA 17540

717.661.3591

www.equipter.com